

University of Kentucky

UKnowledge

Agricultural Engineering Extension Updates

Biosystems and Agricultural Engineering

1997

A Field Curing Structure and Mechanized Housing System for Burley Tobacco

Linus R. Walton

University of Kentucky, lwalton@ca.uky.edu

Larry D. Swetnam

University of Kentucky, larry.swetnam@uky.edu

George A. Duncan

University of Kentucky, gduncan@uky.edu

Follow this and additional works at: https://uknowledge.uky.edu/aeu_reports



Part of the [Bioresource and Agricultural Engineering Commons](#)

[Right click to open a feedback form in a new tab to let us know how this document benefits you.](#)

Repository Citation

Walton, Linus R.; Swetnam, Larry D.; and Duncan, George A., "A Field Curing Structure and Mechanized Housing System for Burley Tobacco" (1997). *Agricultural Engineering Extension Updates*. 6.

https://uknowledge.uky.edu/aeu_reports/6

This Report is brought to you for free and open access by the Biosystems and Agricultural Engineering at UKnowledge. It has been accepted for inclusion in Agricultural Engineering Extension Updates by an authorized administrator of UKnowledge. For more information, please contact UKnowledge@lsv.uky.edu.



AEU-82

A FIELD CURING STRUCTURE AND MECHANIZED HOUSING SYSTEM FOR BURLEY TOBACCO

Two deterrents to expansion of production of burley tobacco are a lack of barn room located conveniently to the tobacco fields and a lack of hired labor for harvesting and housing. In working toward a solution to these problems, engineers from the Biosystems and Agricultural Engineering Department have designed and fabricated a field curing structure with a mechanized housing system. The field curing structure has three rows of posts set in the ground to provide columnar strength for the structure. Cross members are set on top of the columns to support the tobacco when it is placed into the structure. The roofing material, which must be replaced periodically, is spun-bonded polypropylene with a black waterproof coating. This material has provided three to four seasons of life as a roof covering.

The structure is one tier high and 28 feet wide. The field curing structure is easy to construct compared to a conventional barn and is well within the construction capabilities of most producers. The structure requires about 12 to 13 bents for an acre of burley (28 ft x 114 to 125 ft). The cost of the structure is about half that of the conventional barn on a per acre basis.

Wooden beams 14 foot long are used to hold 50 to 60 sticks of burley tobacco with the sticks extending from each side in a cantilever manner. The empty beams are loaded onto the carrier by two workers for transport to the field. These beams, which weigh about 100 pounds, must be tied down for transport to keep them from bouncing from the carrier. A two-wheeled

carrier hauls two beams end-to-end which gives it a capacity of 100 to 120 sticks per load. The carrier has a tractor-operated hydraulic cylinder for raising and lowering the height of the beams, which allows the beams to be positioned at a convenient height for filling in the field and also permits lifting the filled beams at the curing structure for hanging the beams. After the beams are filled and transported to the structure, the carrier with two cantilever beams in tandem is pulled into the structure where the carrier is used to raise the beams into position for attachment to the framework using wire cable. The carrier is lowered and pulled out of the structure where empty beams are loaded onto the carrier. During 1990, two workers housed burley tobacco at the rate of slightly over an acre per day using the system.

The structure can also be tiered to handle tobacco in the conventional manner. Tobacco would be loaded on a conventional wagon or trailer or on a rail wagon for transport to the field curing structure where the tobacco would be hung one tier deep on 4 foot wide tier rails.

Educational programs of the Kentucky Cooperative Extension Service serve all people regardless of race, color, age, sex, religion, handicap, or national origin.

Issued in furtherance of Cooperative Extension work, Acts of May 8 and June 30, 1914, in cooperation with the U.S. Department of Agriculture, C. Oran Little, Director of Cooperative Extension Service, University of Kentucky College of Agriculture, Lexington, and Kentucky State University, Frankfort.

TOBACCO FIELD STRUCTURE - MECHANIZED HOUSING

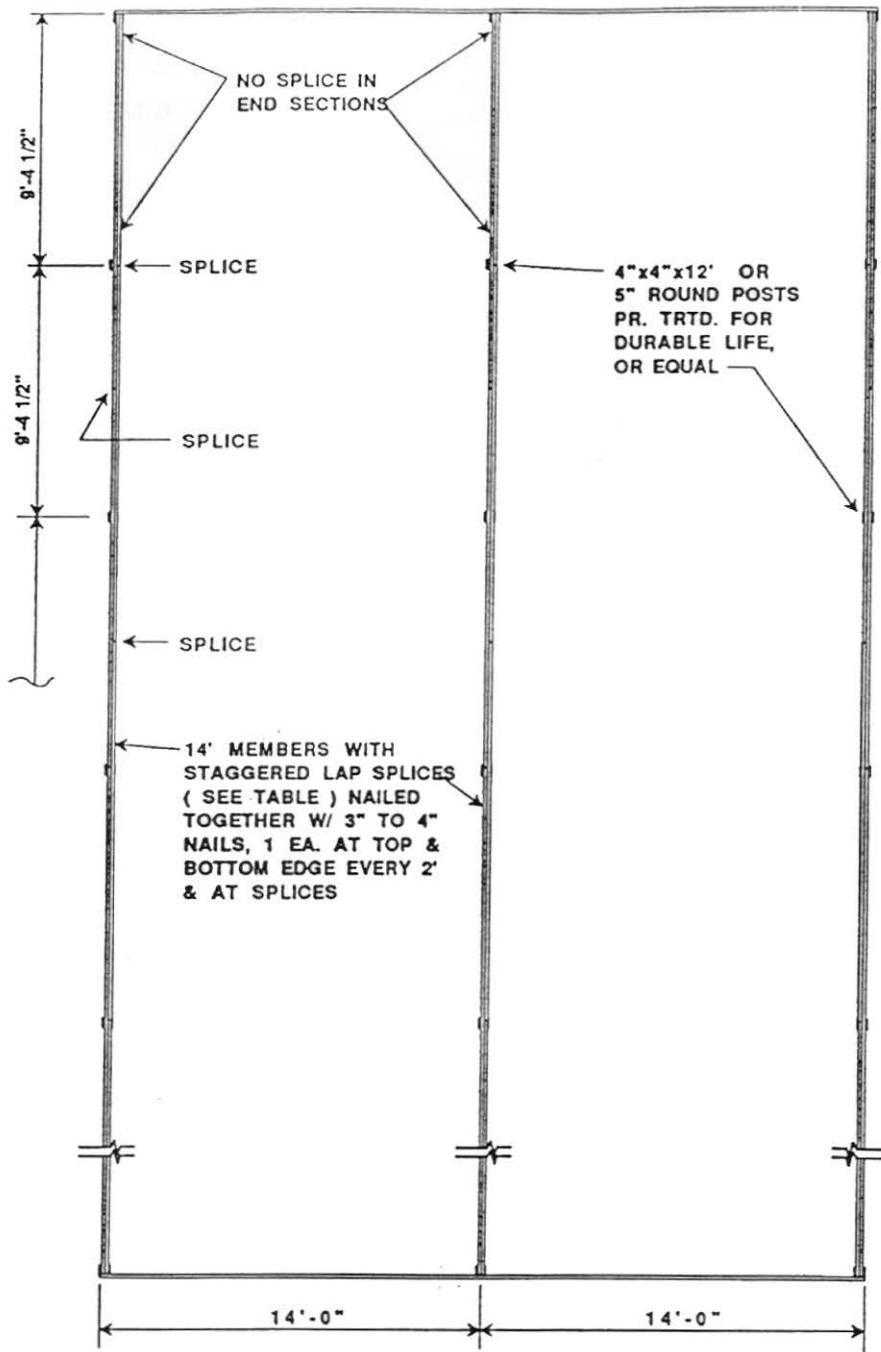

PLAN VIEW

TABLE 1. SIZE OF SUPPORT BEAMS

<u>OUTSIDE</u>	<u>MIDDLE</u>	<u>LUMBER</u>
2-2x8x14'	2-2x10x14'	<u>DRESSED, #2</u>
		OR BETTER
OR 2-2"x6"x14'	2-2"x8"x14'	<u>FULL DIMENSION</u>
		#2 OR BETTER

TOBACCO FIELD STRUCTURE - MECHANIZED HOUSING

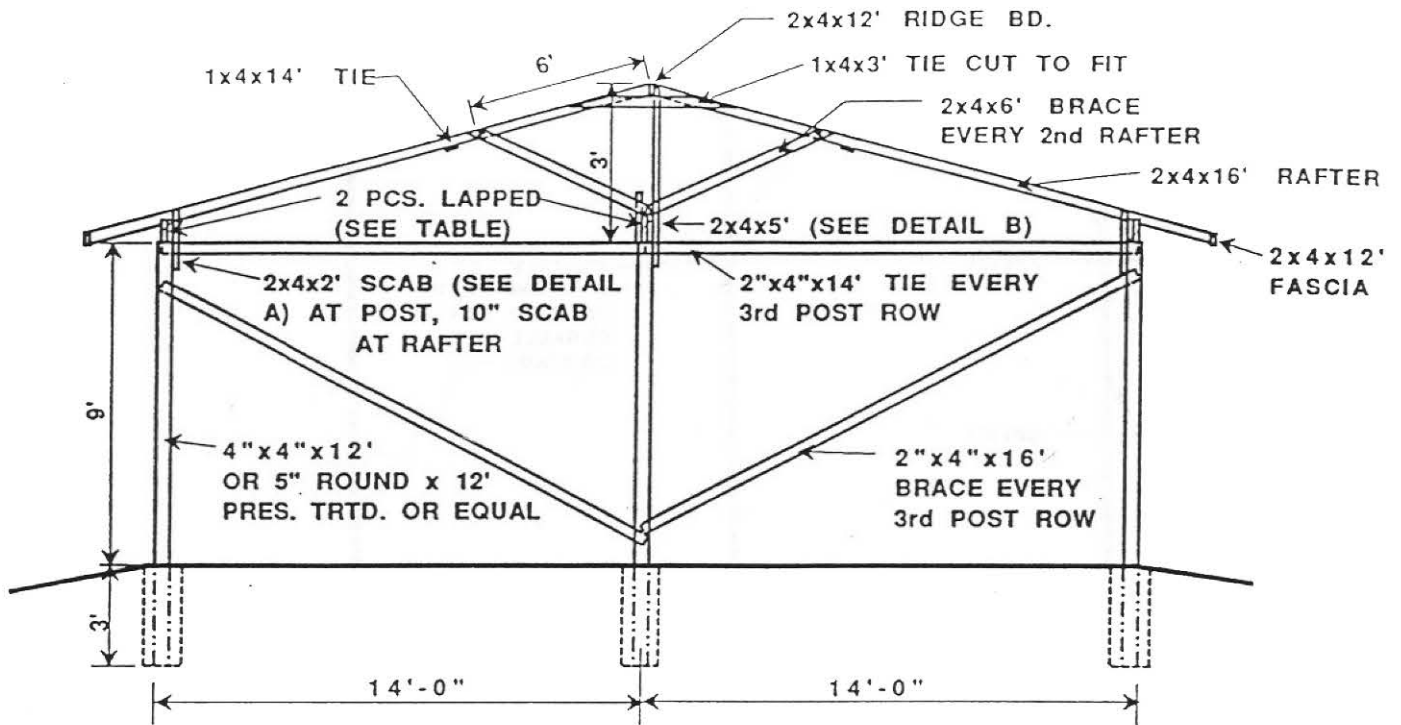

CROSS SECTION

(NO SCALE)

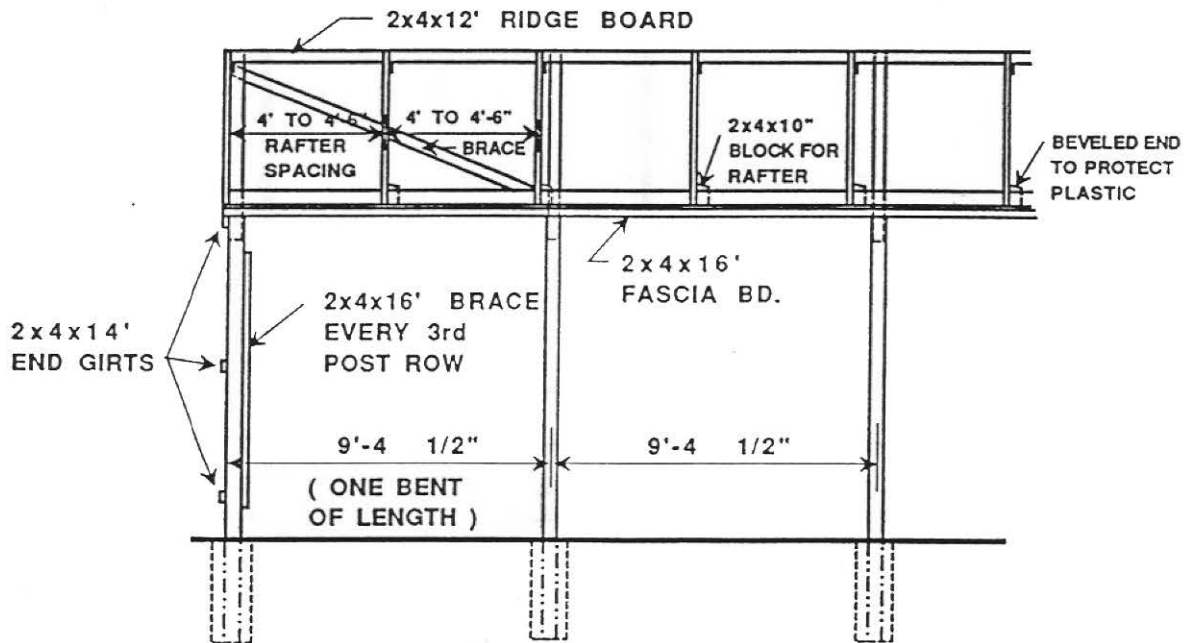

SIDE ELEVATION

(NO SCALE)

TOBACCO FIELD STRUCTURE - MECHANIZED HOUSING

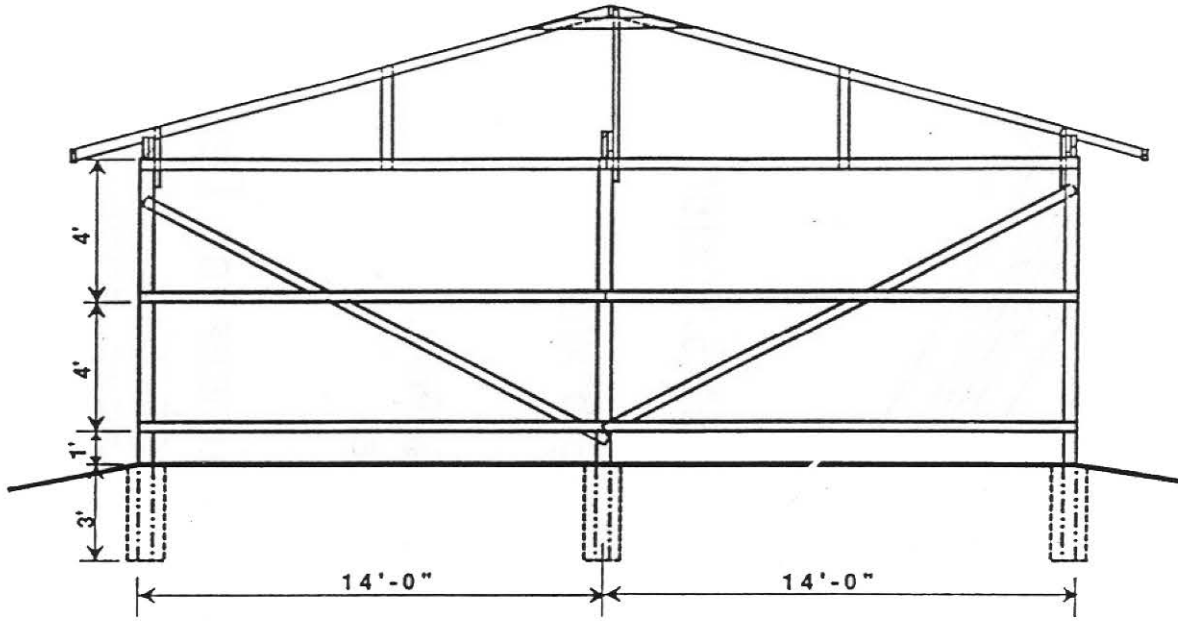

END ELEVATION
(NO SCALE)

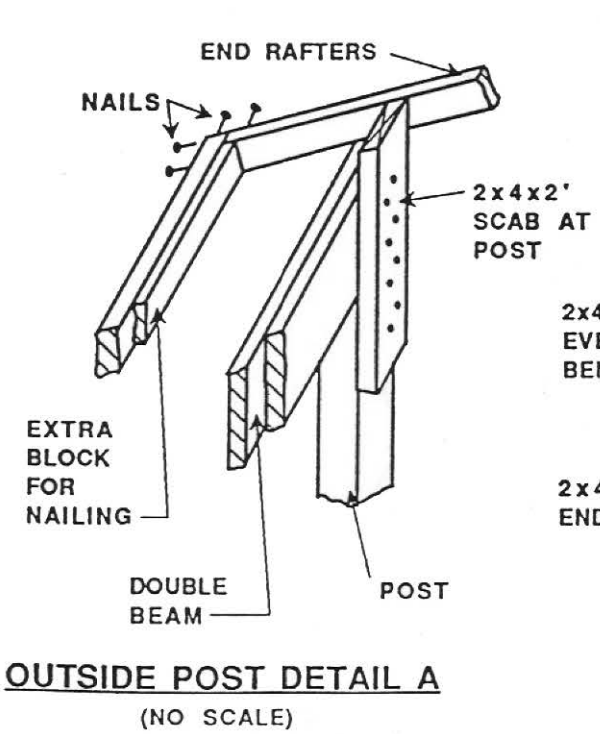

OUTSIDE POST DETAIL A
(NO SCALE)

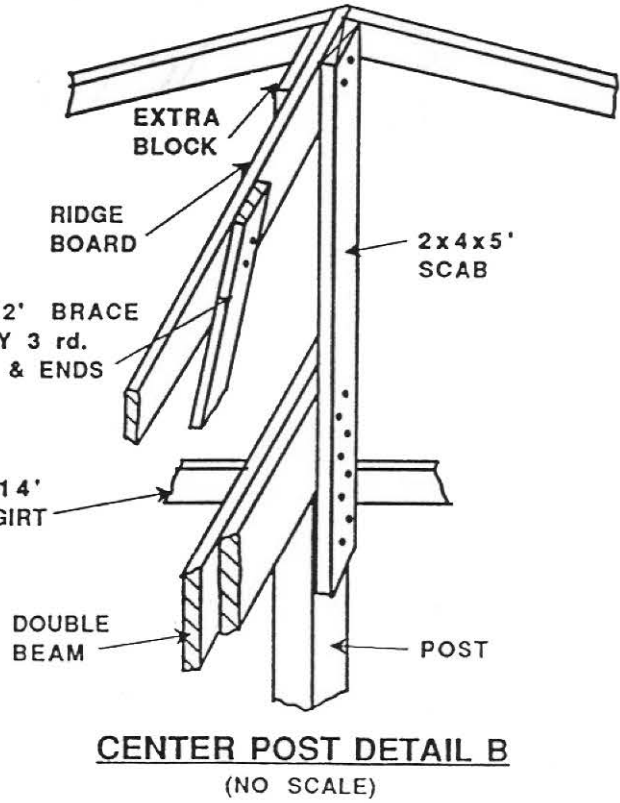

CENTER POST DETAIL B
(NO SCALE)

Cantilevered Tobacco Beam

For Use With
Field Curing Structure

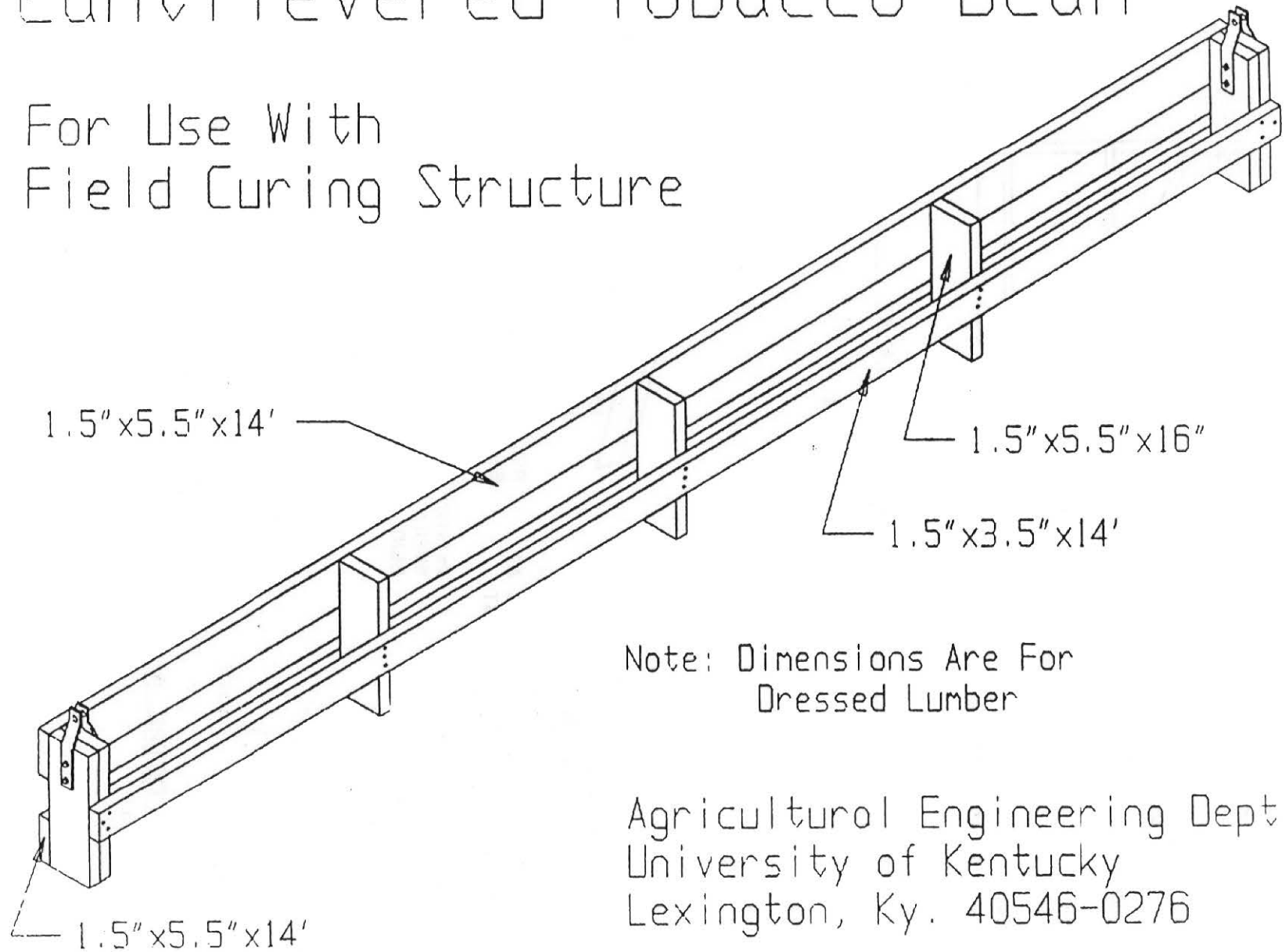

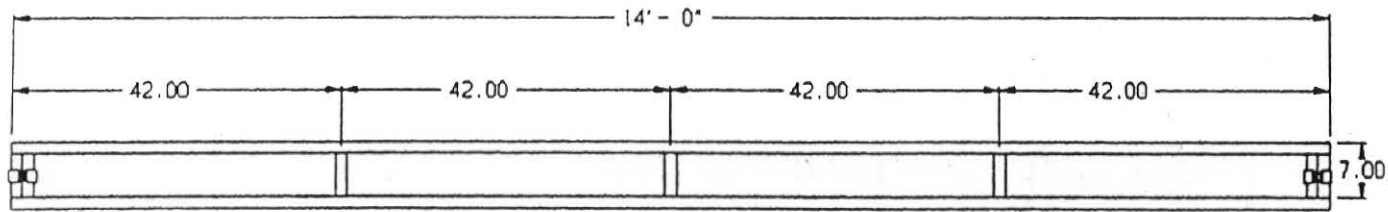

TOP VIEW

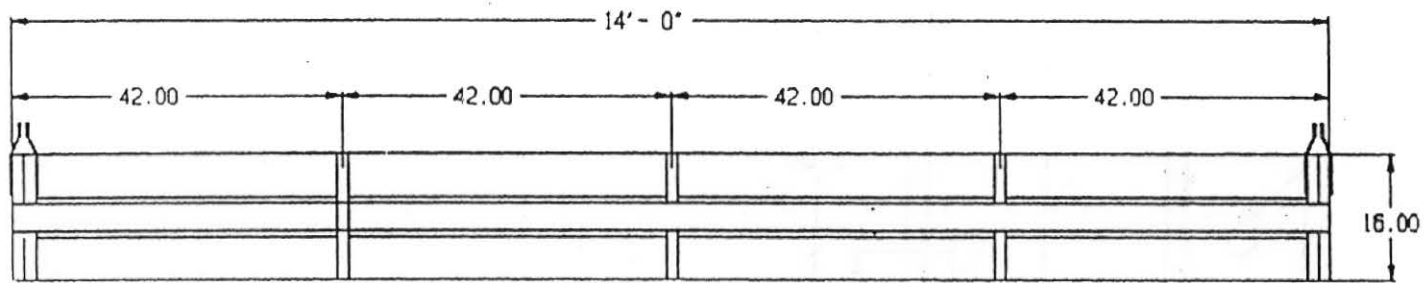

Side View

Agricultural Engineering Dept
University of Kentucky
Lexington, Ky. 40546-0276

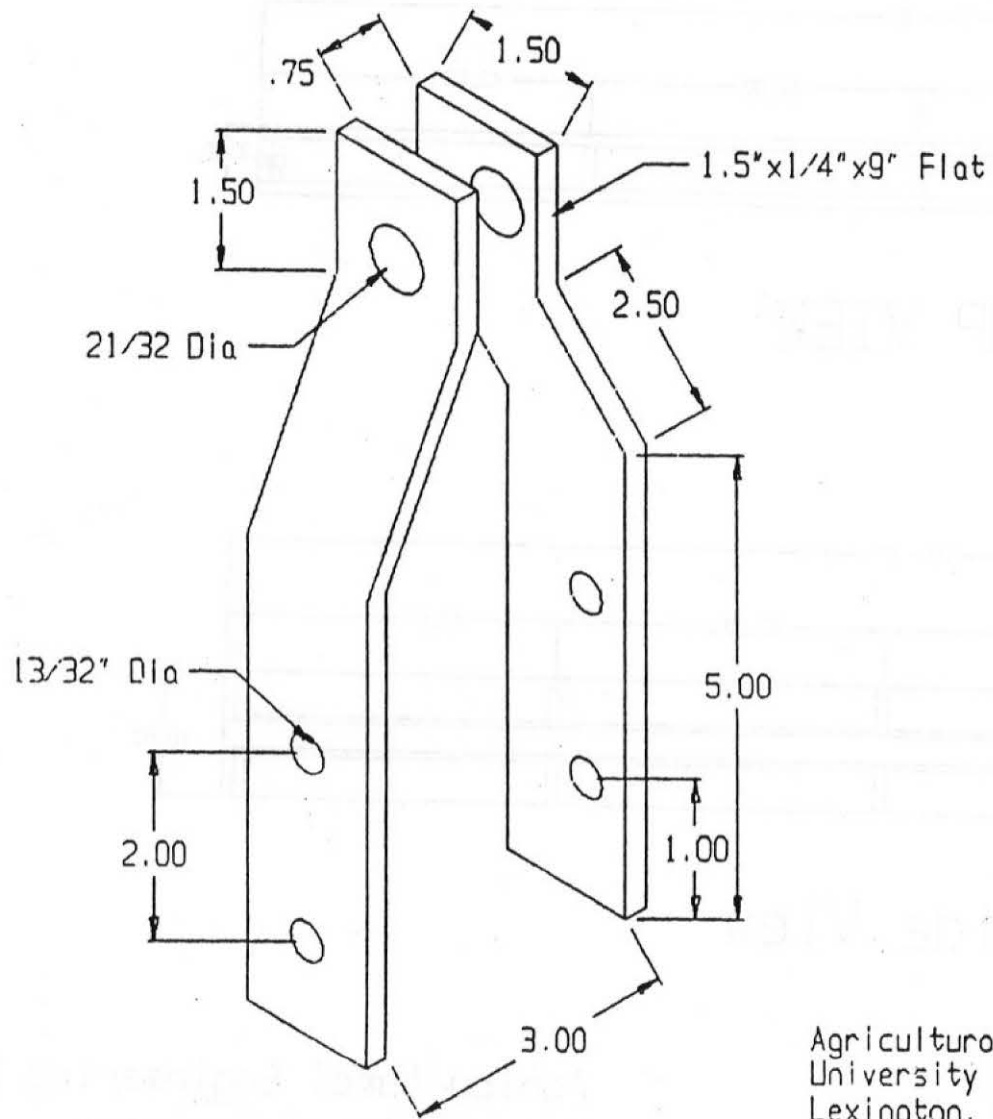

Agricultural Engineering Dept.
 University of Kentucky
 Lexington, Ky. 40546-0276

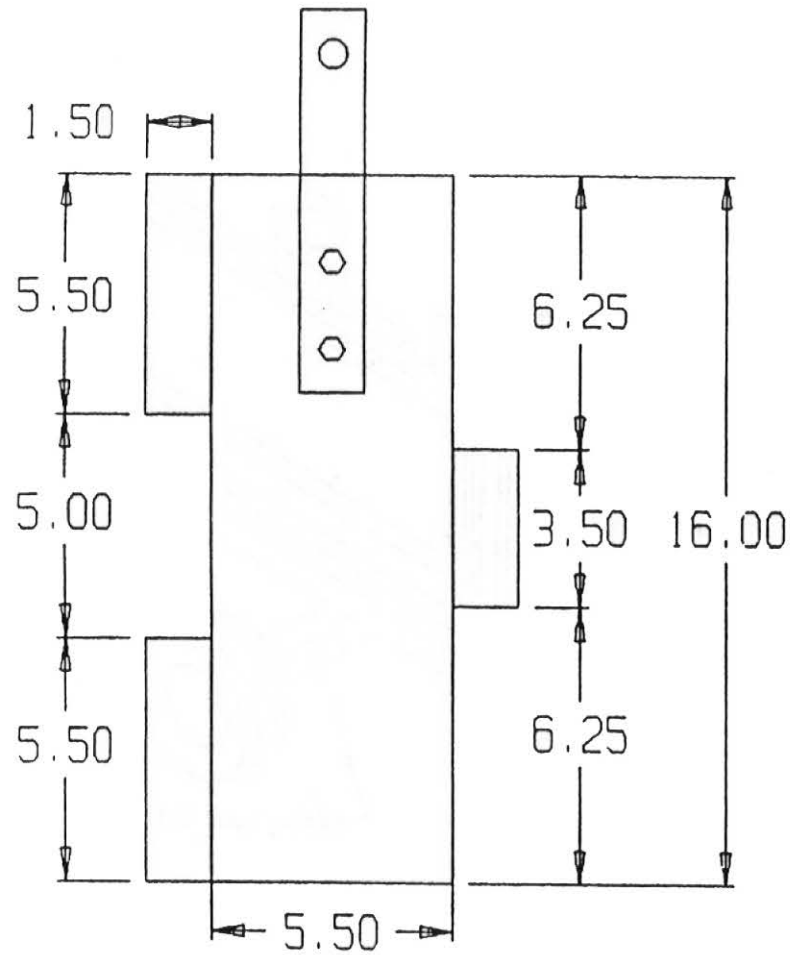

END VIEW

Agricultural Engineering Dept.
 University of Kentucky
 Lexington, Ky. 40546-0276

Beam Carrier

For Use With
Field Curing Structure

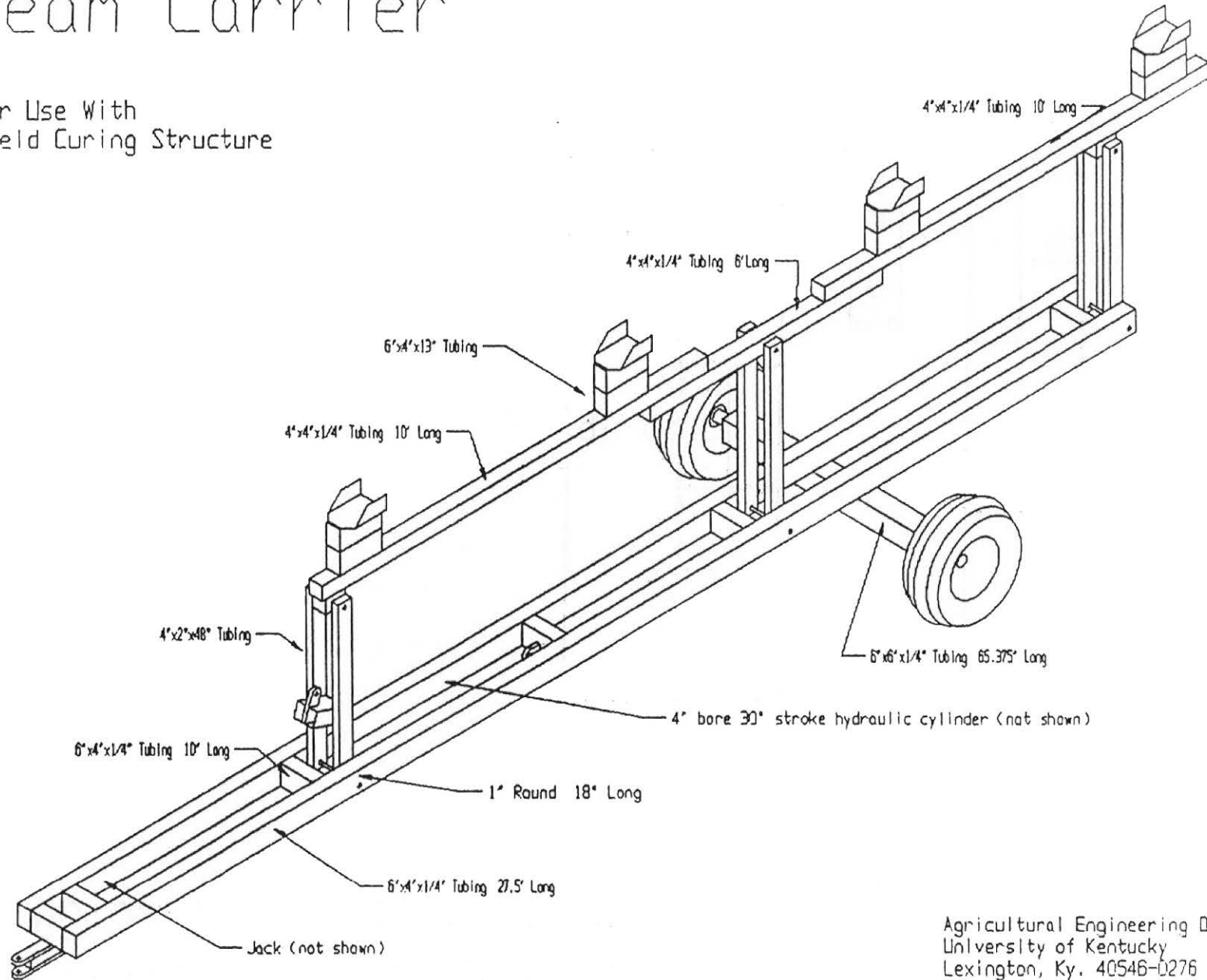

INCOMPLETE DRAWING - REQUEST COPY OF PLAN 735-54 FOR FULL DETAILS.