

University of Kentucky

UKnowledge

---

Power and Energy Institute of Kentucky  
Presentations

Power and Energy Institute of Kentucky

---

7-2021

## Large-Scale Solar PV and Battery Energy Storage Model Study on a Proposed Benchmark Transmission System

Gerald W. Bankes II

University of Kentucky, geraldbankes@gmail.com

Oluwaseun M. Akeyo

University of Kentucky, ochichikeyo@gmail.com

Dan M. Ionel

University of Kentucky, dan.ionel@uky.edu

Follow this and additional works at: [https://uknowledge.uky.edu/peik\\_present](https://uknowledge.uky.edu/peik_present)



Part of the [Power and Energy Commons](#)

[Right click to open a feedback form in a new tab to let us know how this document benefits you.](#)

---

### Repository Citation

Bankes, Gerald W. II; Akeyo, Oluwaseun M.; and Ionel, Dan M., "Large-Scale Solar PV and Battery Energy Storage Model Study on a Proposed Benchmark Transmission System" (2021). *Power and Energy Institute of Kentucky Presentations*. 3.

[https://uknowledge.uky.edu/peik\\_present/3](https://uknowledge.uky.edu/peik_present/3)

This Presentation is brought to you for free and open access by the Power and Energy Institute of Kentucky at UKnowledge. It has been accepted for inclusion in Power and Energy Institute of Kentucky Presentations by an authorized administrator of UKnowledge. For more information, please contact [UKnowledge@lsv.uky.edu](mailto:UKnowledge@lsv.uky.edu).



## Problem Formulation

- The move toward renewable energy sources has led to an increase in the penetration of inverter-based resources onto the transmission system
- Most literature discusses two types of models of IBRs, time-average models, which do not capture high-frequency switching effects, and detailed switching models, which are computationally expensive
- The IEEE 12-Bus test system was modified in PSCAD™/EMTDC™ to include a 100 MW PV facility and 100 MW battery energy storage system (BESS) connected at bus 2.
- The PV facility and BESS are modelled using a proposed dynamic inverter-based resource module
- A demonstration of the module was performed using two transient case studies showing the behavior of the BESS during real and reactive power support of the grid.

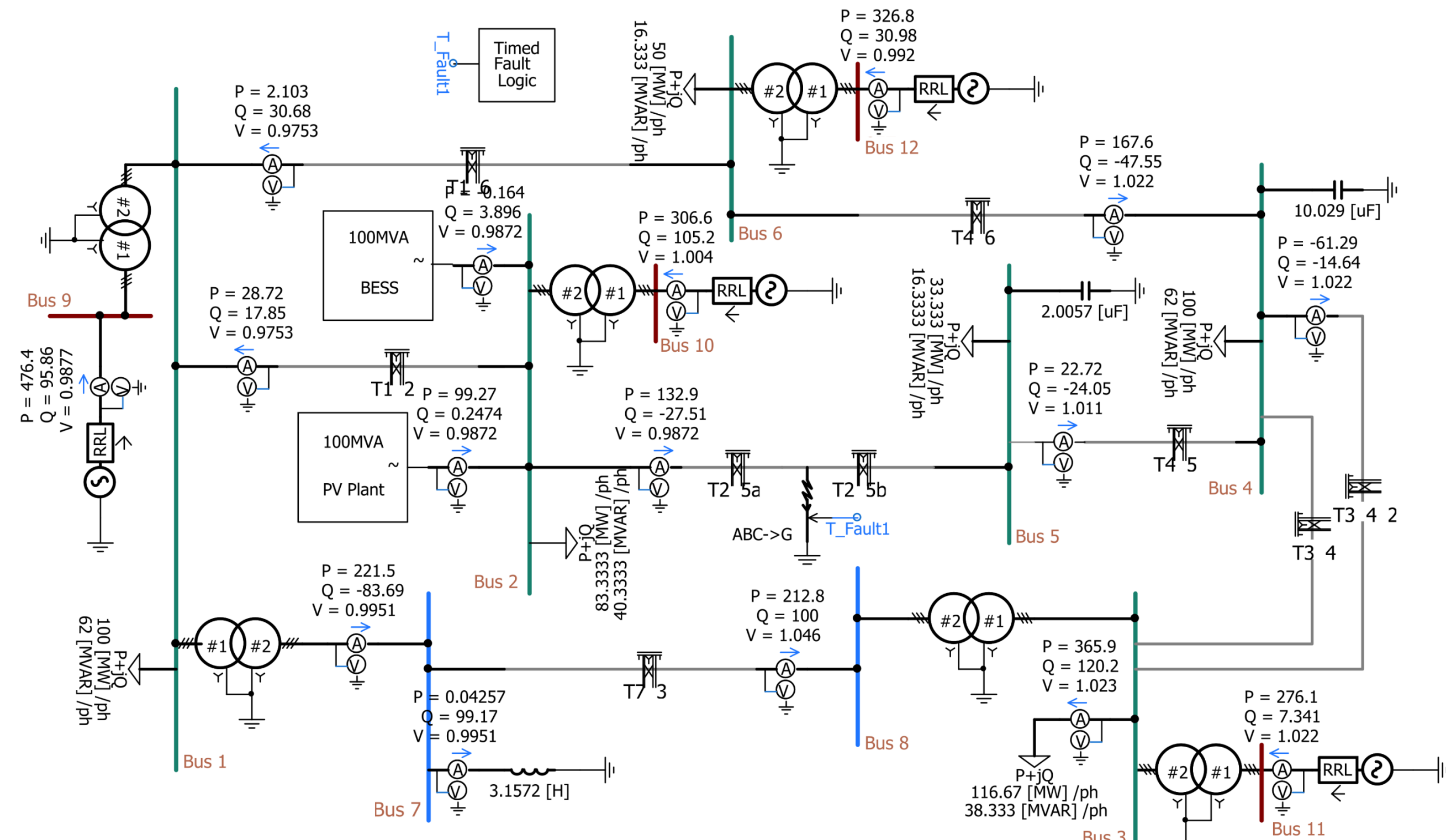

## Dynamic Inverter-Based Resource (IBR) Module

- A dynamic inverter-based resource module was developed for computer simulation of PV, wind and battery energy storage systems
- The dynamic module combines the ability to capture the effect of high frequency power electronics, as in detailed IBR models, with reduced computational complexity, as in time-average IBR models.

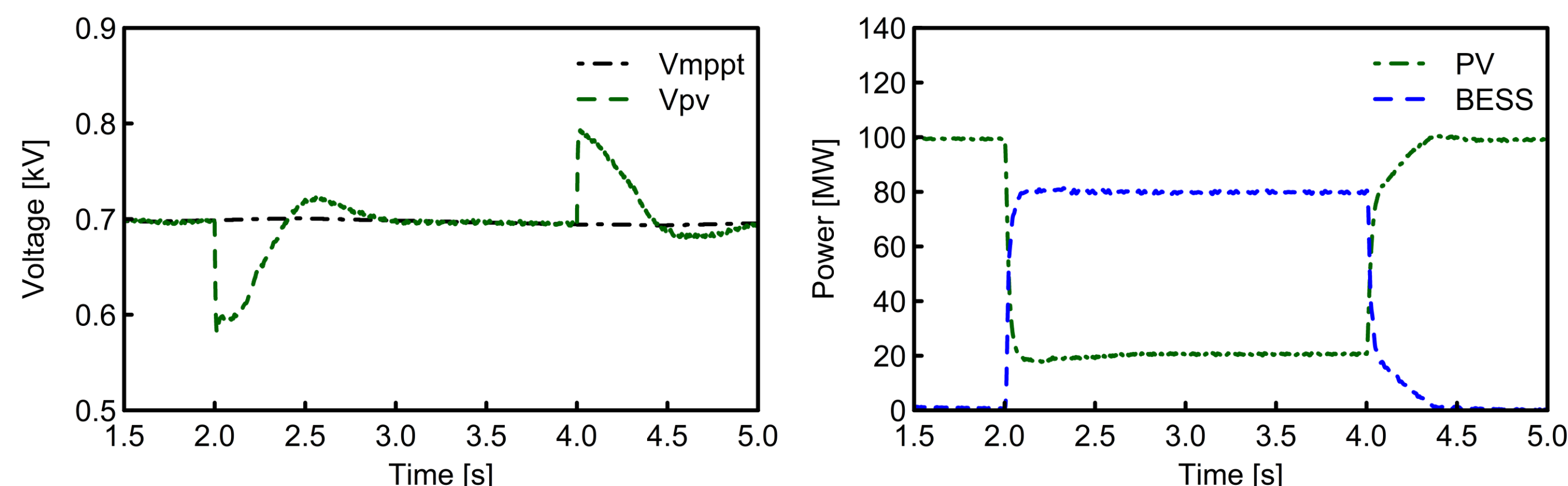
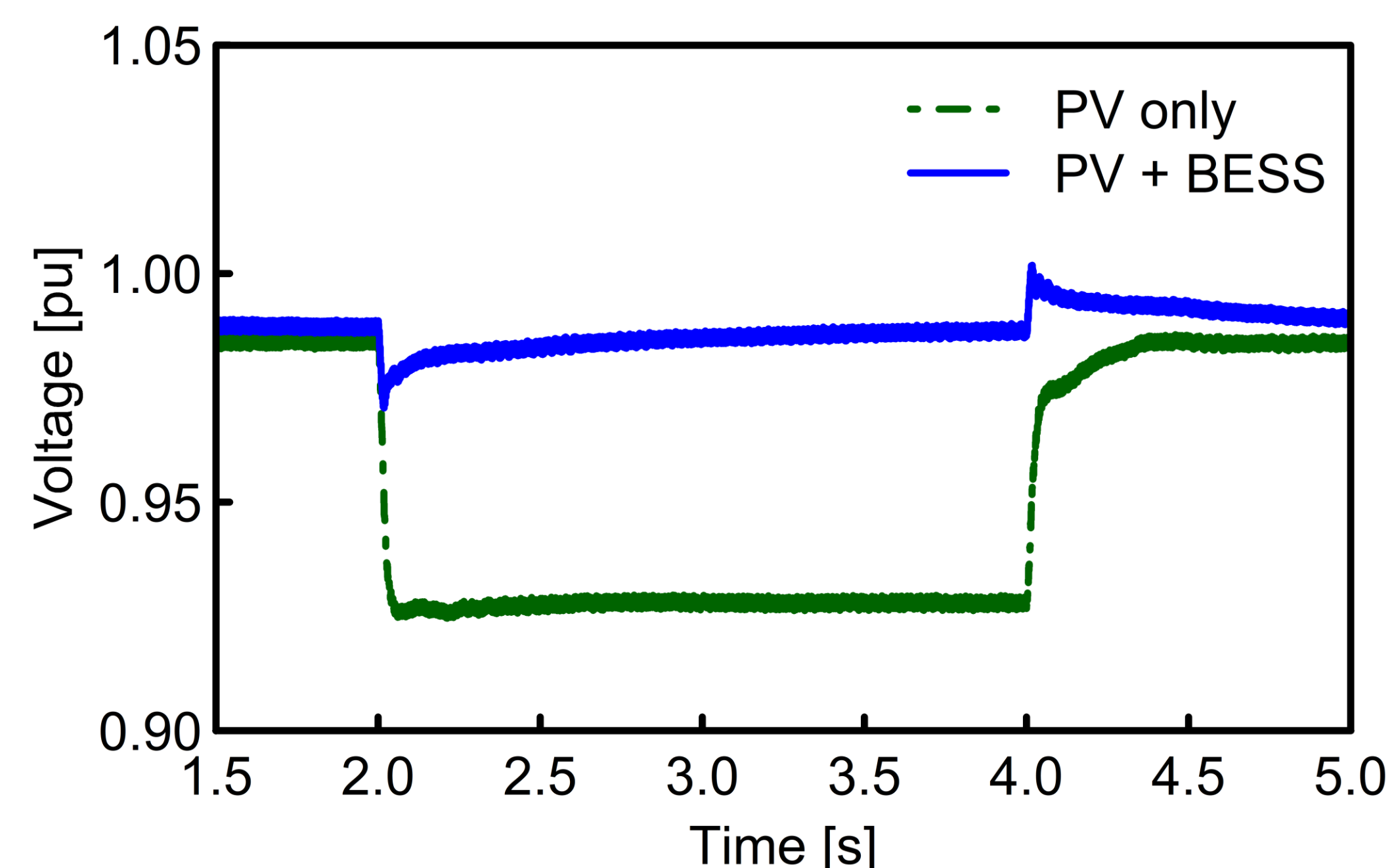
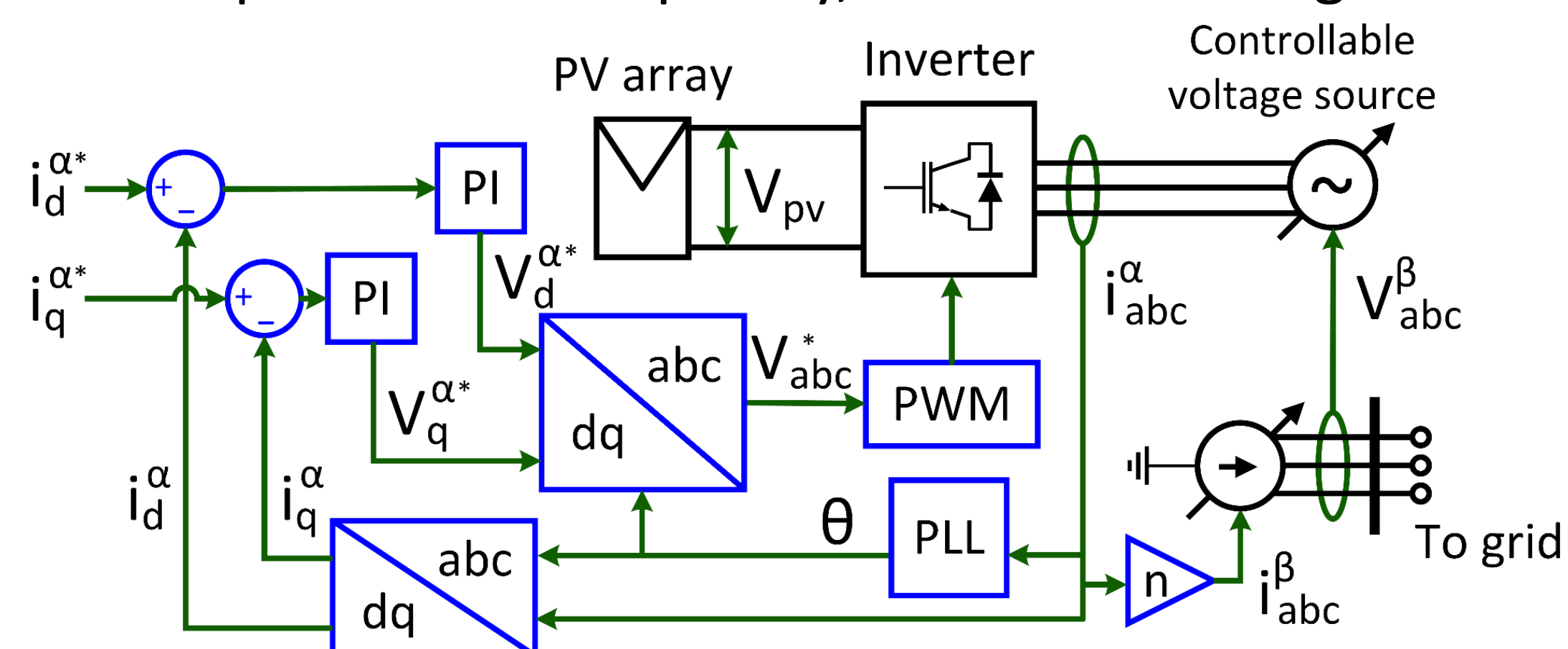

## PV and BESS Transient Shading Response

- The impact of sudden shading on the solar PV plant operation and the response of the BESS system was simulated and analyzed on the modified transmission system
- The solar PV array irradiance was set to suddenly fall from 1000W/m<sup>2</sup> to 200W/m<sup>2</sup> for a duration of 2s at 2s simulation time
- The BESS was set to provide real power support during the condition of shading so that the real power output at the point of interconnection remained constant.
- The bus voltage at the point of interconnection was monitored for two cases: the case of PV with no BESS support and the case of PV along with the BESS in real power support mode
- The simulation results show that the real power support of the battery during the shading condition results in a mitigation of an approximately 0.07 pu voltage drop at bus 2, the point of interconnection.

## BESS Volt-Var Operation

- The impact of transient three-phase transmission line fault conditions on the solar PV plant operation and the response of the BESS system was simulated and analyzed.
- The BESS was configured to absorb reactive power during periods of high bus voltage and vice-versa
- Reactive power support is inactive when the terminal voltage of the battery is between 0.995 and 1.005pu

- The BESS supplies or absorbs half of its reactive power capacity when the terminal voltage is below 0.9pu or above 1.1pu, respectively.
- The reactive power is then linearly interpolated for voltages between 0.9 - 0.995pu and 1.005-1.1pu
- The fault and reduction in PV terminal voltage led to a drop in DC-Link voltage before the controller acted to maintain the reference voltage
- The reactive power support of the battery energy storage system significantly mitigated the voltage drop at the point of interconnection due to the fault

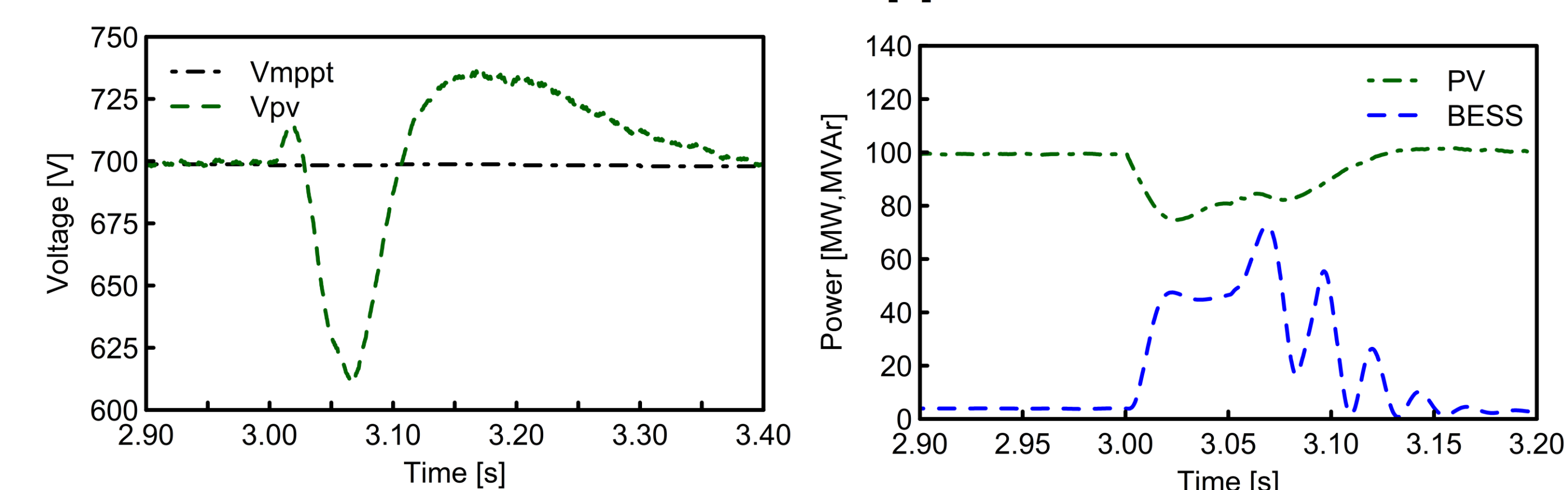
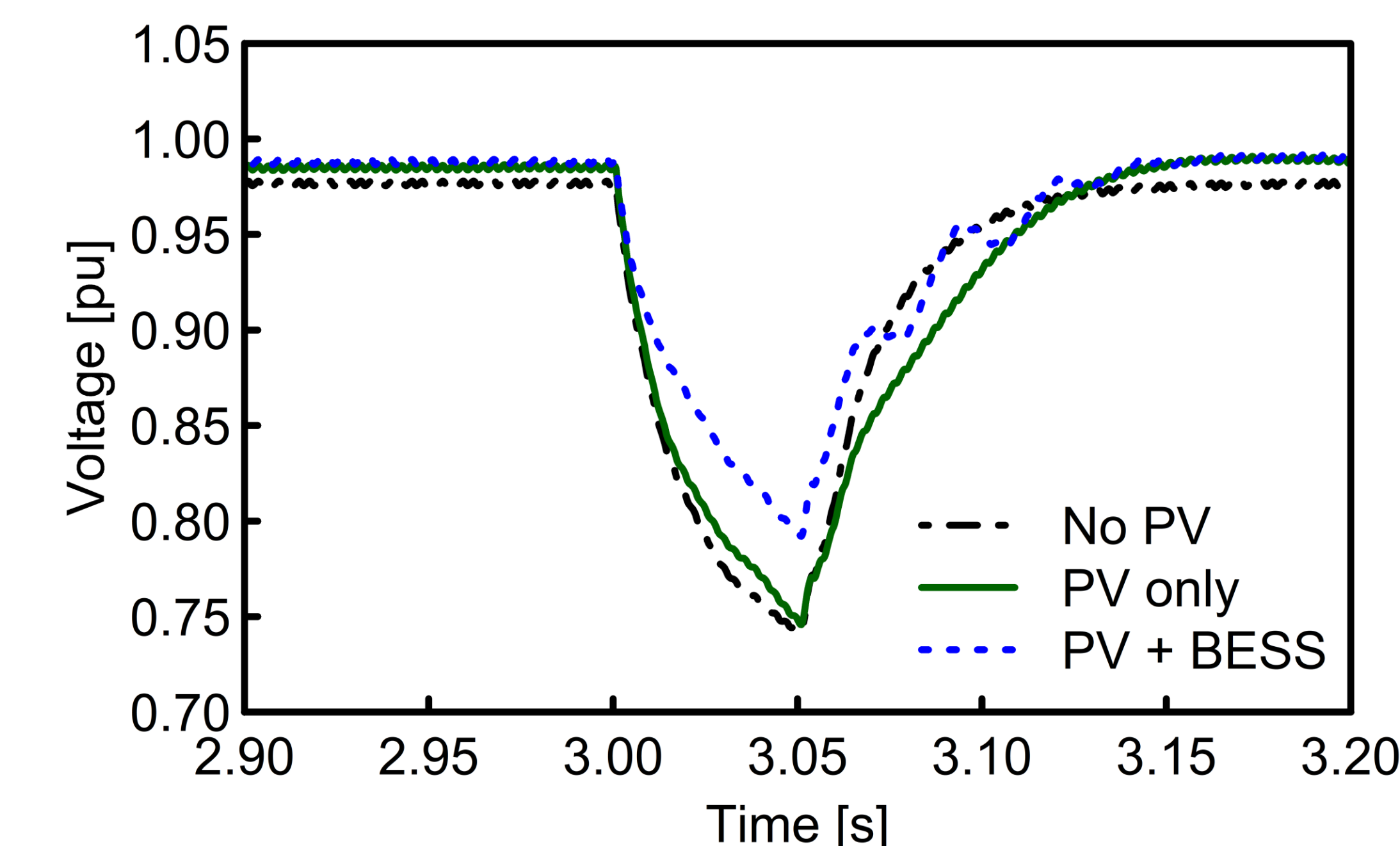

## Conclusions

- A dynamic IBR module was developed to analyze impact of large-scale PV and BES systems on transmission systems
- The dynamic module combines benefits of detailed switching models with time-average models
- The modified IEEE 12-Bus Test system was developed for use in two test cases to demonstrate the benefits of the proposed module
- The simulation of real and reactive power support of the battery shows the module' to be used for transmission system improvements in PV hosting capacity and voltage regulation under conditions of faulting and solar shading.

## Acknowledgement

The support of Louisville Gas and Electric and Kentucky Utilities, part of the PPL Corporation family of companies, and of University of Kentucky, the L. Stanley Pigman endowment is gratefully acknowledged.